



Combination Fire/Smoke Damper • 3 Hr. Rated • Single Thickness Blade • Leakage Class I • 250°F or 350°F Rated • Galvanized Steel

Standard Construction and Materials

- FRAME:** 5½" x ⅞" x 16 GA. galvanized steel hat channel; Flat 16 GA. galvanized head and sill for maximum free area on dampers ≤ 13" high.
- BLADES:** 16 GA. galvanized steel single thickness, parallel action.
- AXLES:** Plated solid steel stub.
- BEARINGS:** Oil impregnated bronze.
- LINKAGE:** Plated steel angle and crank plates with stainless steel pivots, in-jamb type or on-blade type
- STOPS:** 18 GA. galvanized steel angles at head and sill
- BLADE SEALS:** Silicone.
- JAMB SEALS:** Stainless steel.
- SLEEVE:** Minimum 20 GA. galvanized steel by 18" long (sizes greater than 84" wide or 84" high require minimum 18 GA.)
- CAULKING:** Hardcast Irongrip 601 or UL-listed equivalent.
- ACTUATOR:** Electric with heat response device (EHRD) or pneumatic with heat response device (PHRD). Factory-installed for power-open/spring-close (fail close) operation. External left hand mounted as viewed from jackshaft side of damper.
- FINISH:** Mill.

UNDERWRITERS LABORATORIES INC.®
 CLASSIFIED DYNAMIC FIRE AND SMOKE DAMPER
 FIRE RESISTANCE RATING 3 HR
 LEAKAGE RESISTANCE CLASS I

FILE # R6462

This combination fire/smoke damper meets the construction and performance requirements of:

- Underwriters Laboratories Inc. Standard 555 and 555S.
- National Fire Protection Association Standards 80 and 90A.
- ICC's International Building Code.
- California State Fire Marshal Listing #3225-1328:115.
- New York City MEA Listing # 111-99-M.
- Underwriters Laboratories Inc. Approved for dual direction airflow and dynamic conditions.
- Underwriters Laboratories Inc. Classified for use in fire resistive ratings of 3 hours and longer.
- Underwriters Laboratories Inc. Classified for use in smoke control systems for Leakage Class I and 250°F or 350°F.
- Actuators must be arranged to operate automatically, must fail closed upon loss of power, and must be controlled by a smoke detections system.

Options

- Exact size (no undercut)
- Actuators - 120V, 24V, 230V or pneumatic
- Right hand and/or internal actuator mounting locations (restrictions apply)
- Dual Position Indication (DPI) switches
- Sensotherm Re-Openable Heat Response Device (ESOT) for electric actuator
- Sensotherm Re-Openable Heat Response Device (PSOT) for pneumatic actuator
- Model SM-501 flow-rated smoke detector
- Model 2151 no-flow smoke detector (12" minimum damper height)
- Momentary test switch
- Remote test boxes
- Copper tubing (for pneumatic actuators)
- Transformers
- Tab-lock retaining angles - 1 or 2 Sets
- Stainless steel bearings
- Stainless steel axles
- Security bars
- Sleeves of various depths and gauge thickness (restriction apply)
- No sleeves (restriction apply)
- Round or oval transitions
- Short-width (<8") and/or short-height (<6") transitions

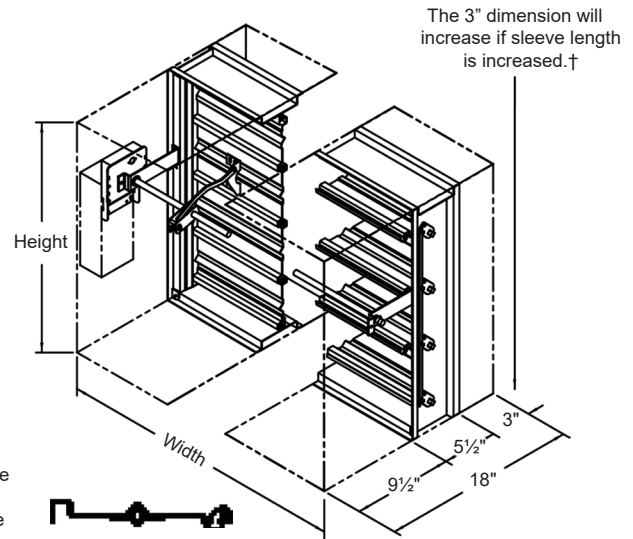

Blade Profile

† See Note 6 for details

Sizing Chart Notes:

- * Dampers smaller than the minimum frame size require a transition. Reference SD-TRFS for details.
- ** For damper sizes smaller than 16"W x 8"H, airfoil blades will be supplied.
- * For a true 6" high, width is limited to 16". When ordered as 6" high and width is less than 16", an 8" high damper with 2" short-height transition will be supplied.

Notes

1. Nominal deductions will be made to the opening size given.
2. Dampers greater than or equal to 12" in height with factory mounted SM-501 smoke detectors require a minimum 19" deep sleeve (10½" on the actuator side); detectors will be mounted on the side of the damper opposite actuator.
3. Dampers less than 12" in height with factory mounted SM-501 smoke detectors require a minimum 20 deep sleeve (11½" on the actuator side); detectors will be mounted on the bottom or top of damper.
4. Smoke detectors can be ordered for field mounting with standard 18" deep sleeve.
5. Dampers for horizontal installation can only be mounted in a fire barrier constructed of masonry/concrete materials.
6. Unless ordered with a smoke detector, the 3" sleeve setback on the non-jackshaft side will increase when sleeve lengths greater than 18" are ordered. Custom non-jackshaft side setback dimensions must be specified on order. When ordered with a smoke detector, additional sleeve length is added to jackshaft side. If ordered with smoke detector and additional sleeve length (beyond requirements of notes 2 and 3), additional sleeve length will be added to jackshaft side unless custom setback dimension is otherwise specified on order.

Damper Sizes

Orientation	Horz & Vert	2000 fpm, 4 in.wg				3000 fpm, 4 in.wg		
		Horizontal		Vertical		Horz & Vert	Horizontal	Vertical
Panels	** Min Panel	Max Single Panel 250°/350°	Max Assy Panel 250°/350°	Max Single Panel 250°/350°	Max Assy Panel 250°/350°	Max. Panel 250°	Max Assy 250°	Max Assy 250°
Rectangular	4"W x 4"H (8"W x 6"H frame)	30"W x 48"H 36"W x 30"H	60"W x 48"H	36"W x 48"H	108"W x 48"H	36"W x 36"H	60"W x 36"H	108"W x 36"H
Round	4" dia. (8"W x 6"H frame)	28" dia.	47" dia.	34" dia.	46" dia.	34" dia.	34" dia.	46" dia.
Oval	4"W x 4"H (8"W x 6"H frame)	28"W x 46"H 34"W x 28"H	58"W x 47"H	34"W x 46"H	106"W x 46"H	34"W x 34"H	58"W x 34"H	106"W x 34"H

In the interest of product development, Cescro Products reserves the right to make changes without notice.



450 Riverside Dr • Wyalusing PA, 18853
 Phone: 570-746-1888 • Fax: 570-746-9286
 www.cescroproducts.com

Combination Fire/Smoke Damper • 3 Hr. Rated • Single Thickness Blade • Leakage Class I • 250°F or 350°F Rated • Galvanized Steel

Operational Ratings

Maximum Differential Pressure: 4 in. w.g.
 Maximum Face Velocity: 2000 fpm (3000 fpm for selected size/actuator combinations)

Leakage Ratings

UL Leakage Class I
 4 cfm per sq.ft. maximum @ 1 in.wg
 8 cfm per sq.ft. maximum @ 4 in.wg

Sound Ratings

The Noise Criterion data below was tested in accordance with ASTM E477.99 in the center octave band.

Noise Criterion (NC)				
Damper Size	Velocity (fpm)			
	1000	2000	3000	4000
12"W x 12"H	31	53	64	71
24"W x 24"H	33	54	65	-

Pressure Drop Ratings

The pressure drop data shown below is based on laboratory conditions. The test setup does not take into account elbows or other duct fittings that are part of every actual duct system. The configuration of the actual duct system immediately upstream and downstream of the damper often contributes more pressure loss than the damper itself.

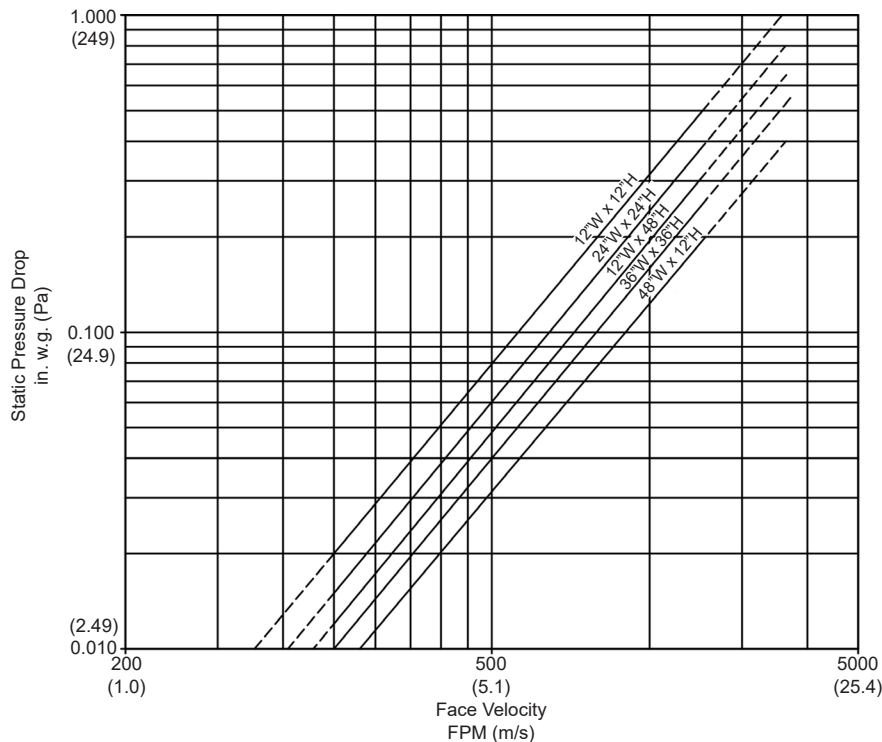

This product was tested in accordance with AMCA Standard 500D, Figure 5.3.

Intake air converted to standard air density.

									
Item #	Qty	Damper Size	Horizontal	Vertical	250°F	350°F	Velocity	Pressure	
			Orientation		Temp. Rating		Operational Rating		Union Made
Arch. / Eng.:					EDR:		ECN:		Job:
Contractor:									
Project:					Date:		DWN:		DWG:



450 Riverside Dr • Wyalusing PA, 18853
 Phone: 570-746-1888 • Fax: 570-746-9286
 www.cescoproducts.com